

REV 更改号	DATE 日期	REVISION DETAILS 更改内容	APPD 审核并批准

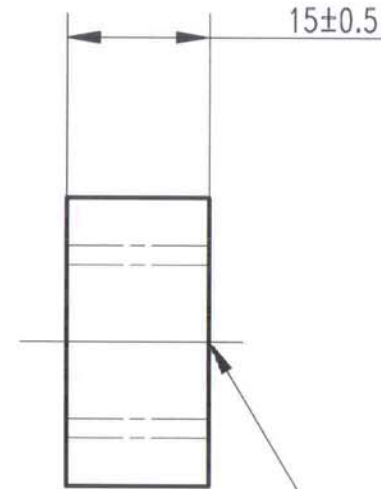
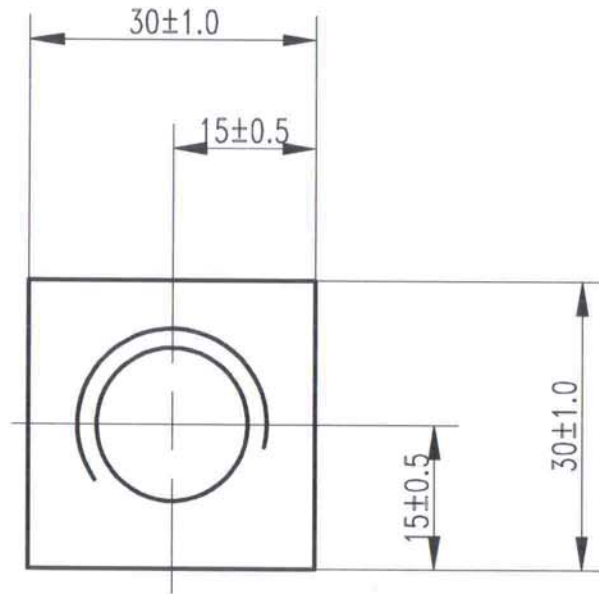

M16 x 2.0-6H

UNLESS SPECIFIED  
ALL DIMENSIONS IN mm,  
MACHINED SURFACES Ra=3.2um,  
ANGLE TOLERANCES ±1°,  
Other tolerance except angles,  
in accordance with  
GB/T1804-2000(ISO2768-1)-m and  
GB/T1184-1996(ISO 2768-2)-m

其它事项  
图示尺寸单位为MM  
未注机加工表面粗糙度为Ra=3.2  
未注角度公差±1°  
其它未注公差（除角度外）均按：  
GB/T1804-2000(ISO2768-1)-M和  
GB/T1184-1996(ISO 2768-2)-m



PART NO 零件名	41151-M16
----------------	-----------

MATERIAL	Chinese steel 45# 材质: 45#
FINISH	Remove all sharp edges ,burns ,silvers and swarf, break all edges 0.127-0.254mm. 去除所有毛刺, 铁屑等残留物, 锐边倒钝0.127-0.254MM ZINC PLATING WITH 12um MICRONS MINIMUM PLATING THICKNESS AND TRIVALENT CHROMATE PASSIVATION AND WITHSTAND 96 HRS TO WHITE / 144 HRS TO RED RUST IN SALT SPRAY TEST. 镀锌, 三价铬钝化, 银白色, 盐雾试验96小时无白锈, 144小时无红锈, 镀锌层厚度大于12um.

SCALE NTS	APPD: 批准: Zhang	DRN 制图: KEVIN	DATE 日期: 2016. 05. 26
	DATE 日期: 25/05/16	CHK 审核: YB. ZHAN	DATE 日期: 2016. 05. 25